

# PRODUCT INFORMATION PACKET

**marathon®**  
Motors

Model No: 056T17WD15330

Catalog No: N433A

PowerWash™ SXT Wash Down Duty™ General Purpose Motor, 1 & 0.75 HP, 3 Ph, 60 & 50 Hz,  
208-230/460 & 190/380 V, 1800 & 1500 RPM, 56C Frame, TEFC



Regal and Marathon are trademarks of Regal Rexnord Corporation or one of its affiliated companies.

©2023 Regal Rexnord Corporation, All Rights Reserved. MC017097E

**RegalRexnord**



### Nameplate Specifications

Phase	<b>3</b>	Output HP	<b>1 &amp; 0.75 Hp</b>
Output KW	<b>0.75 &amp; 0.56 kW</b>	Voltage	<b>208-230/460 &amp; 190/380 V</b>
Speed	<b>1750 &amp; 1450 rpm</b>	Service Factor	<b>1.15 &amp; 1.15</b>
Frame	<b>56C</b>	Enclosure	<b>Totally Enclosed Fan Cooled</b>
Thermal Protection	<b>No Protection</b>	Efficiency	<b>85.5 &amp; 84 %</b>
Ambient Temperature	<b>40 °C</b>	Frequency	<b>60 &amp; 50 Hz</b>
Current	<b>3.2-3/1.5 &amp; 3.0/1.5 A</b>	Power Factor	<b>71.5</b>
Duty	<b>Continuous</b>	Insulation Class	<b>F</b>
Design Code	<b>B</b>	KVA Code	<b>N</b>
Drive End Bearing Size	<b>6205</b>	Opp Drive End Bearing Size	<b>6205</b>
UL	<b>Recognized</b>	CSA	<b>Y</b>
CE	<b>Y</b>	IP Code	<b>55</b>
Number of Speeds	<b>1</b>		

### Technical Specifications

Electrical Type	<b>Squirrel Cage Inverter Rated</b>	Starting Method	<b>Line Or Inverter</b>
Poles	<b>4</b>	Rotation	<b>Reversible</b>
Resistance Main	<b>0 Ohms</b>	Mounting	<b>Round</b>
Motor Orientation	<b>Horizontal</b>	Drive End Bearing	<b>Ball</b>
Opp Drive End Bearing	<b>Ball</b>	Frame Material	<b>Stainless Steel</b>
Shaft Type	<b>T</b>	Overall Length	<b>13.77 in</b>
Frame Length	<b>7.99 in</b>	Shaft Diameter	<b>0.625 in</b>
Shaft Extension	<b>2.06 in</b>	Assembly/Box Mounting	<b>F1 Only</b>
Inverter Load	<b>VARIABLE 10:1</b>		
Outline Drawing	<b>16992600ME</b>	Connection Drawing	<b>00501001ME</b>



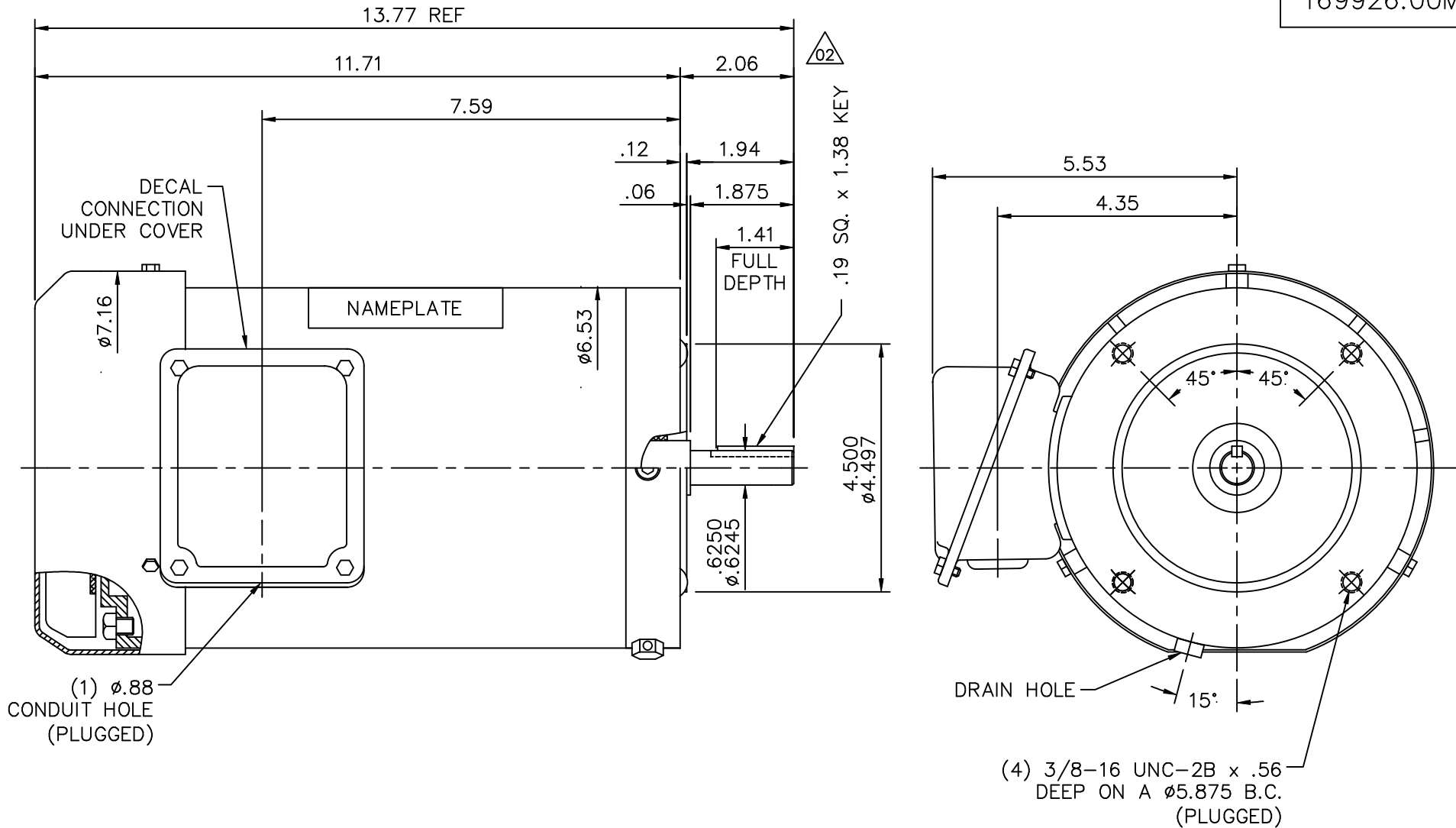

MAXIMUM FACE RUNOUT TO BE .004 T.I.R.  
 MAXIMUM PILOT ECCENTRICITY .004 T.I.R.  
 PERMISSIBLE SHAFT RUNOUT .002 T.I.R.

GASKETS THROUGHOUT

				TOLERANCES UNLESS SPECIFIED			DRAWN MGM 04/09/03			
				DEC.	INCHES		CHK RDW 04/09/03			
				.X	±.1		APPD			
				.XX	±.03	TITLE	OUTLINE - 56C FRAME	SCALE 3=8		
02	UPDATED SHAFT EXT DIMS	RDW 4/26/04	SW	.XXX	±.005		TEFC - "C" FACE	REF		
01	CONDUIT HOLE WAS 1/2-14 NPT, DIM .157 WAS .12	SW 10/7/2003	RDW	.XXXX	±.0005	MAT'L.		FMF		
NO.	REVISION	BY & DATE	CHK	ANG	±1/2"	FINISH		PREV		
THIS DRAWING IN DESIGN AND DETAIL IS OUR PROPERTY AND MUST NOT BE USED EXCEPT IN CONNECTION WITH OUR WORK ALL RIGHTS OF DESIGN AND INVENTION ARE RESERVED THIS IS AN ELECTRONICALLY GENERATED DOCUMENT - DO NOT SCALE THIS PRINT				RFP		CAD FILE	16992600ME	SIZE	DRAWING NO.	REV.
				DIST				A	169926.00ME	01

VIEW FROM OUTSIDE OF MOTOR AT SWITCH END.

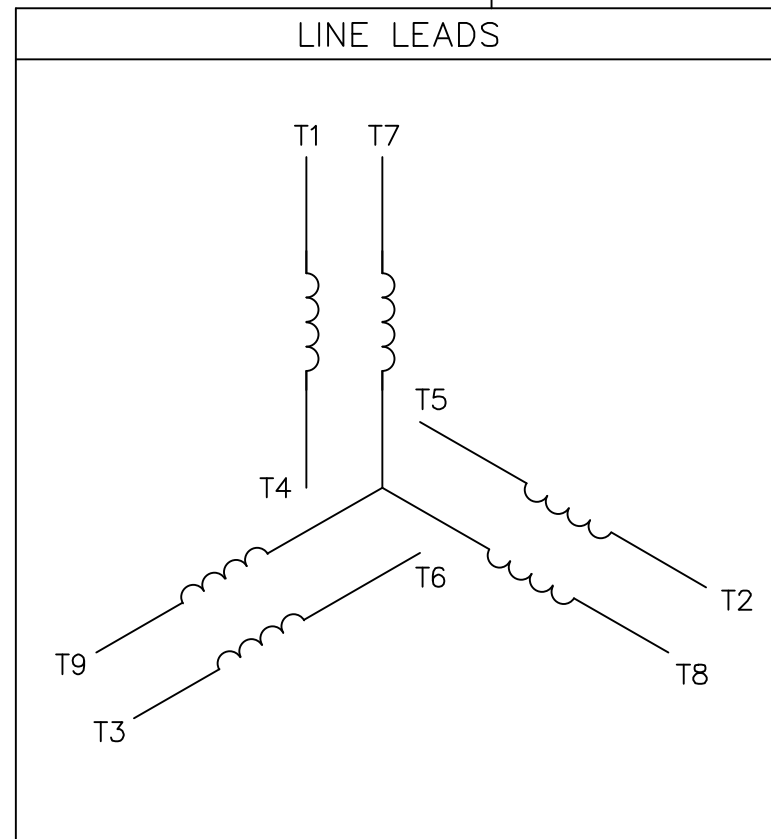
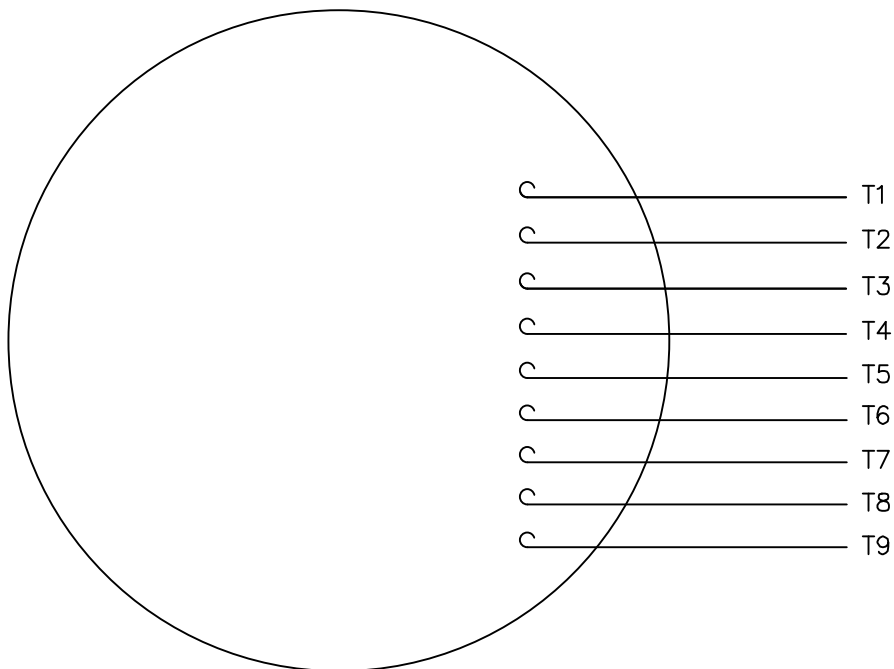

VOLTAGE	L1	L2	L3	JOIN & INSULATE
HIGH	T1	T2	T3	(T4,T7) (T5,T8) (T6,T9)
LOW	T1,T7	T2,T8	T3,T9	T4,T5,T6

		TOLERANCES UNLESS SPECIFIED		MARATHON ELECTRIC		DRAWN RDW 04/12/02		
		DEC.	INCHES			CHK		
		.X	±.1			APPD		
		.XX	±.01	TITLE		SCALE 1=1		
		.XXX	±.005	EXTERNAL WIRING DIAGRAM 3 PHASE W/O PROTECTOR		REF FIG.2-51		
		.XXXX	±.0005	MAT'L.		FMF		
			±1/2"	DECAL - 004014		PREV		
NO.	REVISION	BY & DATE	CHK	ANG	FINISH	SIZE	DRAWING NO.	REV.
			RFP	04/12/02	CAD FILE	A	005010-01ME	
			DIST		00501001ME			

THIS DRAWING IN DESIGN AND DETAIL IS OUR PROPERTY AND MUST NOT BE USED EXCEPT IN CONNECTION WITH OUR WORK ALL RIGHTS OF DESIGN AND INVENTION ARE RESERVED THIS IS AN ELECTRONICALLY GENERATED DOCUMENT - DO NOT SCALE THIS PRINT

**CERTIFICATION DATA SHEET**

Model#: 56T17WD15330 A WINDING#: QT63420 FR 3  
 CONN. DIAGRAM: 00501001ME ASSEMBLY: F1 ONLY  
 OUTLINE: 16992600ME

**TYPICAL MOTOR PERFORMANCE DATA**

HP	KW	SYNC. RPM	F.L. RPM	FRAME	ENCLOSURE	KVA CODE	DESIGN
1&3/4	.75&.56	1800	1750&1450	56C	TEFC	N	B

PH	Hz	VOLTS	FL AMPS	START TYPE	DUTY	INSL	S.F	AMB°C	ELEVATION
3	60/50	208- 230/460#190/ 380	3.2- 3/1.5&3.0/1.5	LINE OR INVERTER	CONTINUOU S	F5	1.15/1.15	40	3300

FULL LOAD EFF: 85.5&84	3/4 LOAD EFF: 86.1	1/2 LOAD EFF: 83.4	GTD. EFF	ELEC. TYPE	NO LOAD AMPS
FULL LOAD PF: 71.5&69.5	3/4 LOAD PF: 62.8	1/2 LOAD PF: 51.1	0	SQ CAGE INV RATED	2 / 1

F.L. TORQUE	LOCKED ROTOR AMPS	L.R. TORQUE	B.D. TORQUE	F.L. RISE°C
2.99 LB-FT	30.2 / 15.1	13.17 LB-FT 440	15.83 LB-FT 529	0

SOUND PRESSURE @ 3 FT.	SOUND POWER	ROTOR WK^2	MAX. WK^2	SAFE STALL TIME	STARTS /HOUR	APPROX. MOTOR WGT
- dBA	- dBA	0 LB-FT^2	- LB-FT^2	10 SEC.	-	0 LBS.

**\*\*\* SUPPLEMENTAL INFORMATION \*\*\***

DE BRACKET TYPE	ODE BRACKET TYPE	MOUNT TYPE	ORIENTATION	SEVERE DUTY	HAZARDOUS LOCATION	DRIP COVER	SCREENS	PAINT
C-FACE	STANDARD	ROUND	HORIZONTAL	FALSE	NONE	FALSE	NONE	NO PAINT

BEARINGS		GREASE	SHAFT TYPE	SPECIAL DE	SPECIAL ODE	SHAFT MATERIAL	FRAME MATERIAL
DE	OPE						
BALL	BALL	POLYREX EM	T	NONE	NONE	303 STAINLESS (C-501)	STAINLESS STEEL
6205	6205						

THERMO-PROTECTORS				THERMISTORS	CONTROL	SPACE /n HEATERS
THERMOSTATS	PROTECTORS	WDG RTDs	BRG RTDs			
NONE	NOT	NONE	NONE	NONE	FALSE	NONE VOLTS

If Inverter equals NONE, contact factory for further information

INVERTER TORQUE: VARIABLE 10:1
INV. HP SPEED RANGE: NONE
ENCODER: NONE
NONE NONE
NONE NONE PPR
BRAKE: NONE NONE
NONE P/N NONE
NONE NONE
NONE FT-LB NONE V NONE Hz

\*  
N  
O  
T  
E  
S  
\*

DATE: 06/29/2017 06:56:49 AM  
 FORM 3531 REV.3 02/07/99  
 \*\* Subject to change without notice.

**Data Sheet**

Date: 1/2/2019  
 Customer: \_\_\_\_\_  
 Attention: \_\_\_\_\_  
 Submitted by: FAREEDA DUDEKULA



56T17WD15330

**Submittal**

Data @ 460 V

**Motor Load Data**

Load	0%	25%	50%	75%	100%	115%	125%	LR
Current (Amps)	1.00	1.00	1.10	1.30	1.50	1.70	1.80	15.1
Torque (ft-lb)	0.00	0.74	1.48	2.23	2.99	3.5	3.8	13.2
RPM	1800	1790	1779	1768	1757	1,750	1745	0
Efficiency (%)		74.5	83.4	86.1	86.9	84.5	86.8	
P.F. (%)	7.7	31.6	51.1	62.8	71.9	74.9	75.0	55.8

**Motor Speed Data**

	LR	Pull-Up	BD	Rated	Idle
Speed (RPM)	0	193	1264	1757	1800
Current (Amps)	15.1	14.8	10.1	1.50	1.00
Torque (ft-lb)	13.2	10.5	15.8	2.99	0.00

**Information Block**

HP	1.0			
Sync. RPM	1800			
Frame	56			
Enclosure	TEFC			
Construction	TS			
Voltage	208-230/460#190/380 V			
Frequency	60 Hz			
Design	B			
LR Code letter	N			
Service Factor	1.15			
Temp Rise @ FL	33 °C			
Duty	CONT			
Ambient	40 °C			
Elevation	3300 feet			
Rotor/Shaft wk <sup>2</sup>	0.00 Lb-Ft <sup>2</sup>			
Ref Wdg	QT63420 FR			
Sound Pressure @ 1M	999 dBA			
VFD Rating	VARIABLE 10:1			
Outline Dwg	16992600ME			
Conn. Diag	00501001ME			
Additional Specifications:				
0				
0				
EQUIV CKT (OHMS / PHASE)				
R1	R2	X1	X2	Xm
0.0000	0.0000	0.0000	0.0000	0.0000

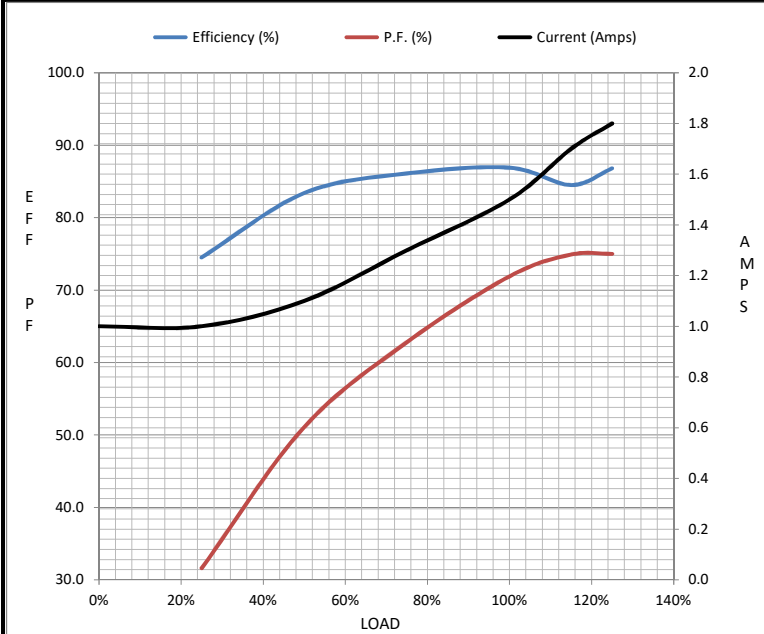

**Speed - Torque Curve**

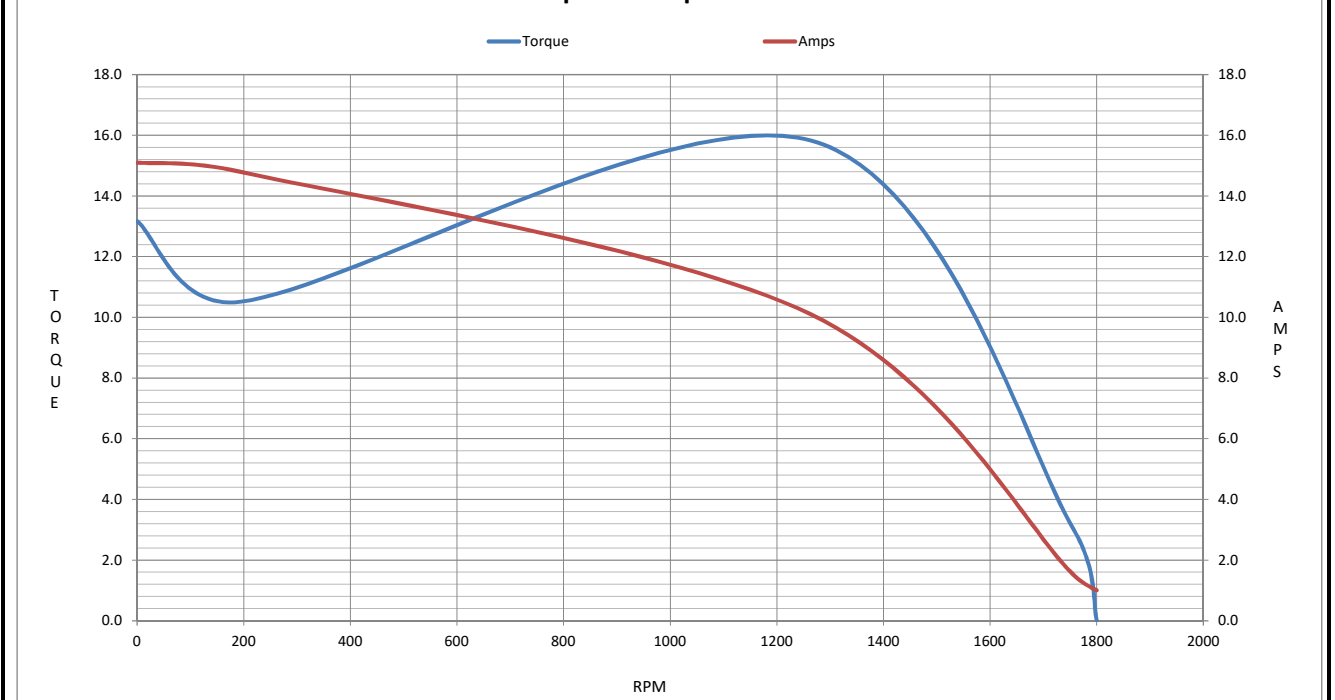

## EC Declaration of Conformity

The undersigned representing  
the manufacturer:

Regal Beloit America  
100 East Randolph St.  
Wausau, WI 54401

and the authorized representative  
established within the Community:

Marathon Electric UK  
6F Thistleton Road Ind. Estate  
Market Overton  
Oakham, Rutland LE15 7PP UK

are committed to providing customers with products that comply with applicable regulations and international protocols to which they are subject, including the requirements of the European Parliament Directive on the Harmonization of the laws relating to electrical equipment designed for use within certain voltage limits (2014/35/EU).

Regal Beloit America declares that the following product(s), to which this declaration relates, are in conformity with the relevant sections of the EC standards listed below.

This statement supersedes any statements previously issued pertaining to the product(s) listed below and is subject to change without notice.

Model No : 056T17WD15330

(Model No. may contain prefix and/or suffix characters)

Catalog No : N433A

Rework No : N/A

Directives :

Low Voltage Directive 2014/35/EU

Harmonized Standards Used :

EN 60034-1: 2010 (IEC 60034-1: 2010)

EN 60034-5: 2001/A1:2007 (IEC 60034-5: 2000/A1:2006)

Authorized Representative:

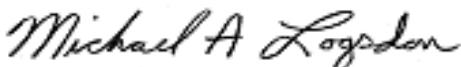

Michael A. Logsdon  
Vice President, Technology

Authorized Representative in the Community:



Julian Clark  
Marketing Engineer

Created on 09/06/2022

**CE 22**